

8 7 6 5 4 3 2 1

REVISIONS			
REV.	DESCRIPTION	DATE	APPROVED

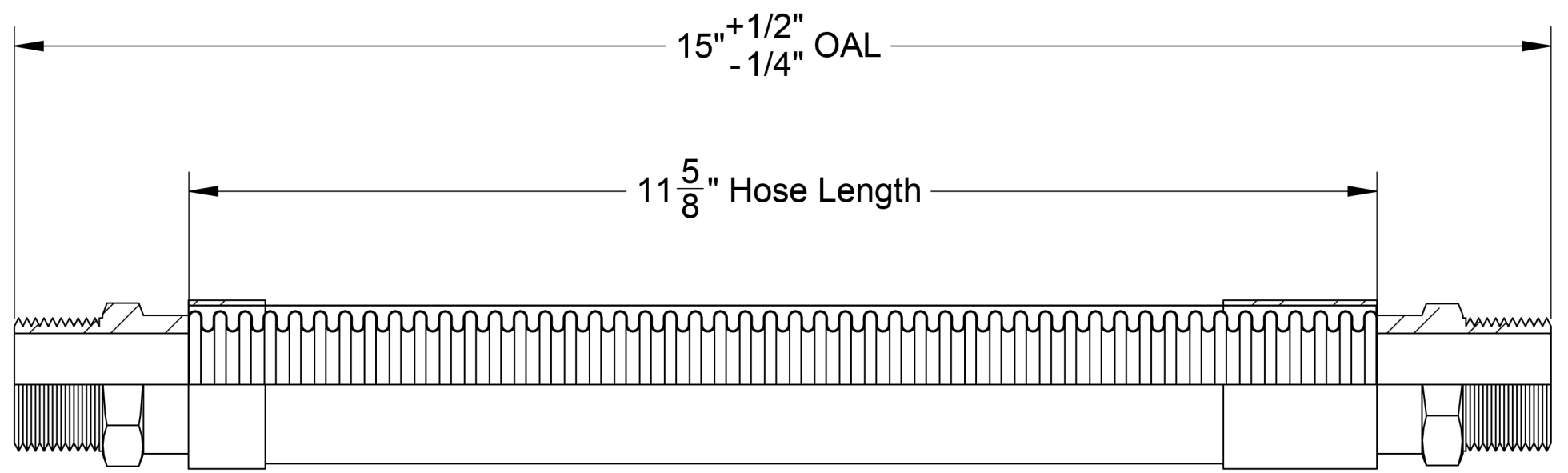

ITEM #	QTY.	PART NUMBER	DESCRIPTION	MATERIAL	WEIGHT
1	1	HOSE	300 Series Stainless HYDROFORMED Corrugated Hose	Stainless Steel	0.28
2	1	BRAID	300 Series Stainless Steel	Stainless Steel	0.03
3	1	BRAID COLLAR	0.05" Thick	Stainless Steel	0.05
4	1	BRAID COLLAR 2	0.05" Thick	Stainless Steel	0.11
5	2	1" MALE	1" Male, 1"x11-1/2" Thread, 1.38" Hex	Stainless Steel	0.27

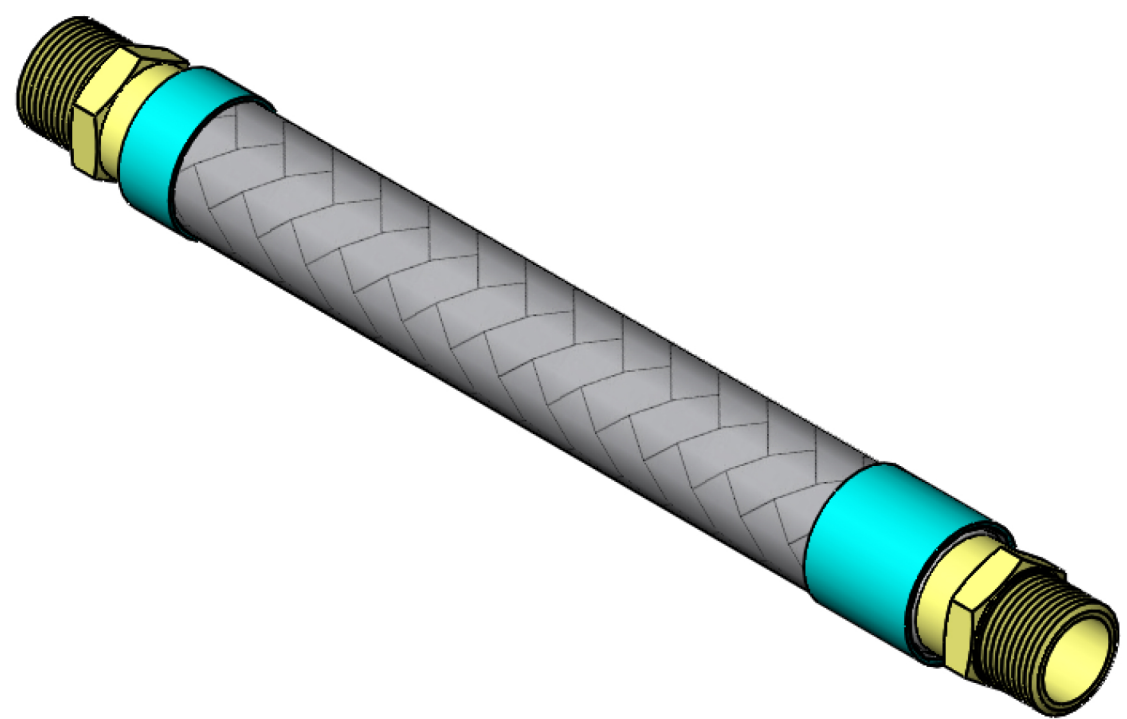

HOSE MASTER Inc.
 1233 East 222nd Street • Cleveland, Ohio 44117
 (800) 221-2319 • Fax: (216) 481-7557 • www.hosemaster.com
 Locations: **Cleveland • Houston**

Registered to:
ISO 9001 : 2000

NAHAD
Listed Manufacturer

Projection:	Customer: Hose Master Inc.	Prepared By: kannk
	Reference: Fire-Shield - 1" Male x 1" Male x 15" OAL	CALC. WEIGHT: 1 lbs. Date: 9/24/2009

Description:
1" ID x 15" OAL 300 Series Stainless HYDROFORMED Corrugated Hose covered by 300 Series Stainless Braid. UL Approved 1" Male Connectors

Drawing #:	FSMM0100x15	Rev.:	-	SHEET 1 OF 1
------------	--------------------	-------	---	--------------

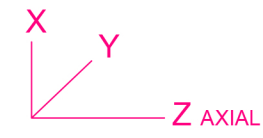

8 7 6 5 4 3 2 1